



BRACK-CM-800

Ceiling Mount Bracket

KEY FEATURES:

- Built of aluminum alloy and SECC material, it is cost-effective.
- With its internal wiring, it is compact and suitable for a variety of cameras.
- It can be scaled from 475 to 800 mm.

SPECS	
Material	SECC; aluminum alloy
Product Dimensions	Φ125.9 mm × 475.0 mm–Φ125.9 mm × 800.0 mm (Φ4.96" × 18.70"– Φ4.96" × 31.50")
Color	White
Net Weight	0.60 kg (1.32 lb)
Gross Weight	0.79 kg (1.74 lb)
Load Bearing	1.0 kg (2.20 lb)
Installation	Ceiling mount
Packaging Dimensions	155.0 mm × 155.0 mm × 490.0 mm (6.10" × 6.10" × 19.29") (L × W × H)

ENVIRONMENT	
Operating Temperature	–40 °C to +60 °C (–40 °F to +140 °F)
Operating Humidity	< 90% (RH)
Storage Temperature	–40 °C to +60 °C (–40 °F to +140 °F)
Storage Humidity	10%–90% (RH)
Anti-corrosion Level	Basic Protection

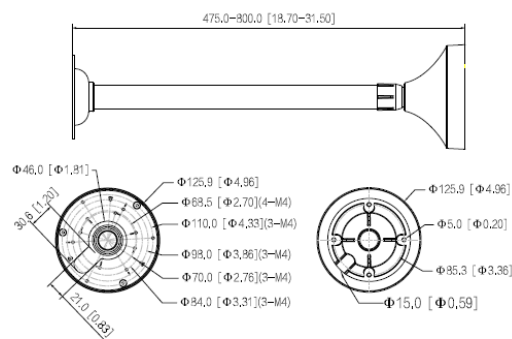

CANADA

351 Ferrier Street Unit 5
Markham, Ontario L3R 5Z2
Tel. 416-410-6865
Toll Free: 1-866-843-6865

USA

171 Cooper Ave. Suite 110
Tonawanda, New York 14150
Tel. 716-877-7277
Toll Free: 1-866-843-6865

MIDDLE EAST

PO Box No 126312
Suite 703 Oxford Tower
Business Bay, Dubai, UAE
Tel. + 971-4-2767117

www.watchnetinc.com
info@watchnetinc.com