

Mini-high Speed Dome

Installation and Operation Manual

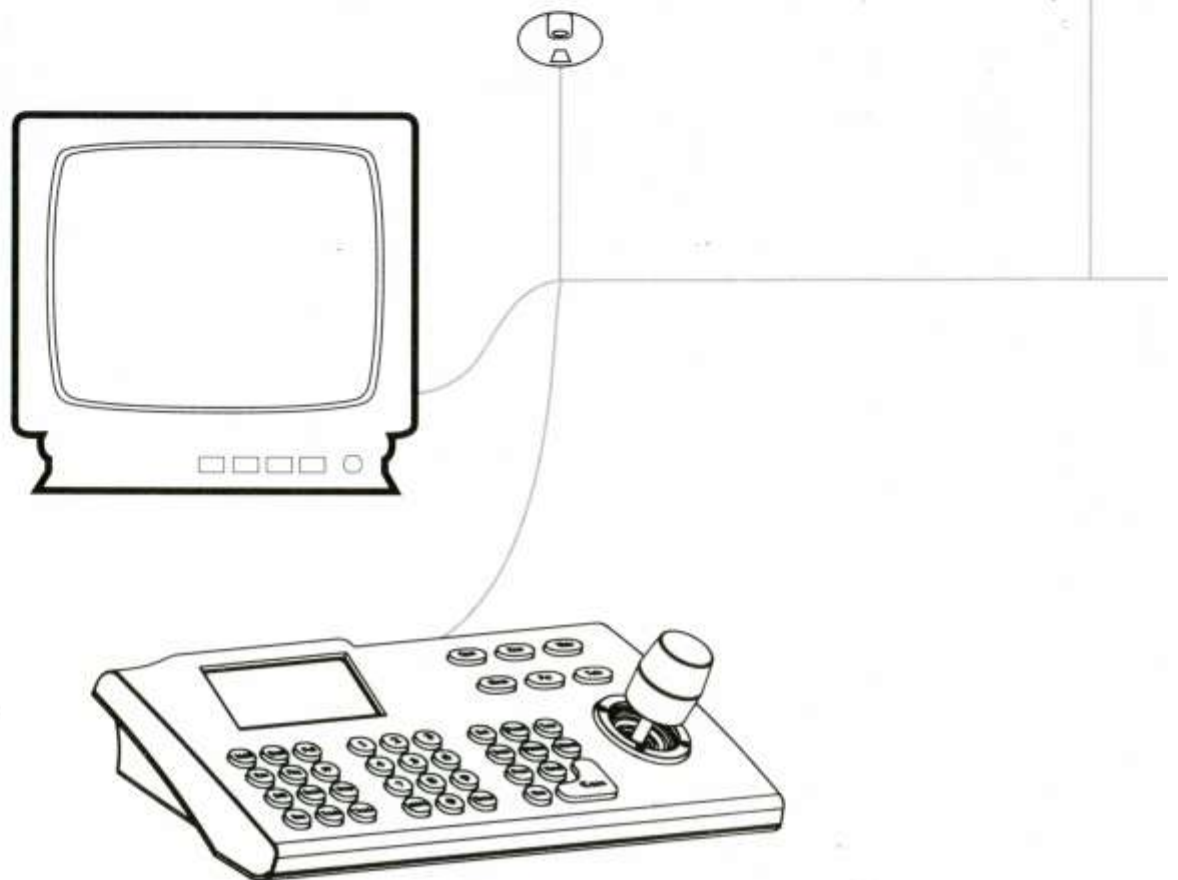

TABLE OF CONTENT

1. Precaution-----	1
2. Installation instruction-----	2
2.1 Ceiling mount-----	2
2.2 Wall mount-----	3
3. Performance & Feature-----	5
3.1 Dome parameter-----	5
3.2 Camera parameter-----	5
3.3 Dome performance&Feature-----	6
4. Function instruction-----	7
4.1 Auto execute function-----	7
4.2 Camera control-----	7
4.3 monitor function-----	8
4.4 constant temperature function-----	8
5. System setting-----	9
5.1 Basic operation-----	9
5.1.1 Self-testing-----	9
5.1.2 Call the main menu-----	9
5.1.3 Basic operation of menu and keyboard-----	9
5.2 Edit dome label-----	10
5.3 Display initial information-----	12
5.4 Display setup-----	13
5.5 Systematic motion control-----	13
5.5.1 Auto-flip-----	13
5.5.2 Speed proportion-----	13
5.5.3 Park action-----	14
5.5.4 Power up action-----	14
5.5.5 Fan startup by temperature-----	14
5.5.6 Head-up mounting setting-----	14
5.6 Clear-----	15
5.7 Password setting-----	16
5.8 Date and clock setting-----	17
5.9 Setup dome parameter-----	18
6. Camera setting-----	19
6.1 Zoom speed-----	19
6.2 Digital zoom control-----	20
6.3 Back light compensation-----	21
6.4 Slow shutter control-----	22
6.5 Ir cut filter -----	23
6.6 Advance setting -----	24
6.6.1 AE mode -----	24
6.6.2 White balance mode -----	25
6.6.3 Camera menu setting -----	25

7. Function setting-----	26
7.1 Preset setting-----	26
7.2 Scan-----	27
7.3 Pattern-----	28
7.4. Tour-----	29
7.5 Zone setting-----	30
7.6 Tour Time Setting-----	31
8. Privacy zone masking-----	32
9. Appendix-----	33
9.1 Menu index-----	33
9.2 Trouble shooting-----	34
9.3 The cleaning of the transparent cover-----	34
9.4 Rs485 Bus basic knowledge-----	35
10. Maintenance-----	37

1. Precaution



Please read the manual and product label carefully before installing the speed dome.

> Law

1. The product installation and use of the product must comply with the relevant laws of the country.

> Electrical safety

1. Strictly conform to country and local electrical safety standard when using or installing the product.
2. Using factory's power adapter. This dome uses DC12V/1500mA power supply. About the rated input voltage, please refer to power label.

> Transportation

1. The dome should be protected against extremes of pressure, vibration humidity and other damage during storage and transportation.
2. This dome is packed as a whole part. When the buyer send it back to factory to maintain, the damage caused by improper transportation is not within the warranty.

> Installation of care

1. Please refer to user manual when installation, and sufficient strength of the wall or ceiling should be ensured.
2. Power must be cut off when installation.
3. Please handle with care ,do not squeeze and press structure parts, which may cause mechanical damage.
4. Down cover and lens of camera are precise optical items. Please don't touch it directly to avoid scratch which will affect the image quality.

> Requirements to service personnel

1. All the service work should be done by qualified technicians.

> Do not disassemble the pan/tilt module

> Environmental requirements

Operation environment temperature: -10°C - $+50^{\circ}\text{C}$

Humidity: <95%



Air pressure: 86-106Kpa

> Don't place lens of the camera to strong light objects(like sun etc.)

> Cleaning of down cover

1. when the image is unclear or there is too much dust on the down cover, please use soft cloth to clean or please use the water to wash the down cover and then wipe up.

1.2 Item no corresponding sheet

Picture	Mount	Place
	Ceiling	Indoor only
	Wall	Indoor and outdoor

1.3 details of relevant parts

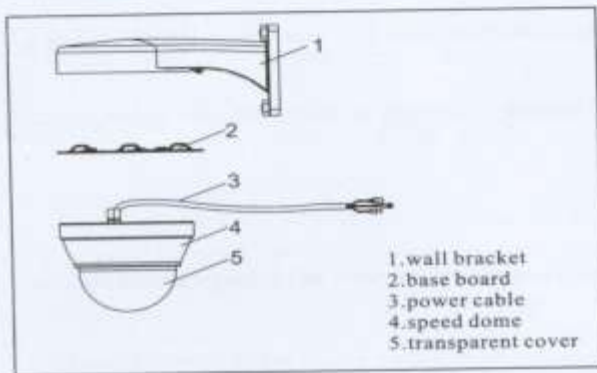

Picture 1-1

2. Installation instruction

2.1 Ceiling mount

1. Dimension of product as picture below

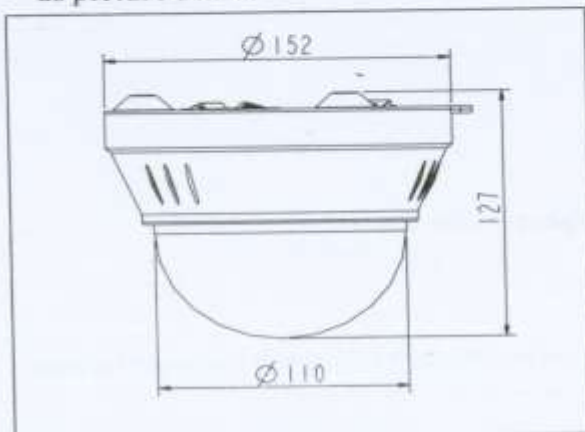

Picture 2-1

2. Installation of product

1. Get the products out from the packages.
As Picture 2.1-1

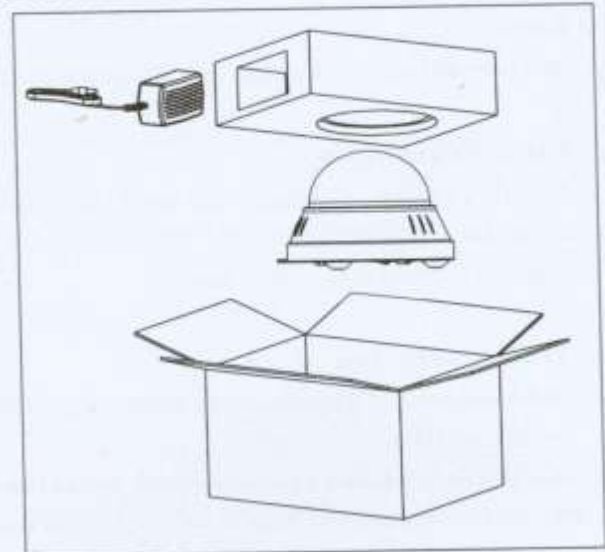

Picture 2. 1-1

2. Drill holes and fix base board on the ceiling floor by using of 3 M4 bolts.(Like picture 8.2-2)

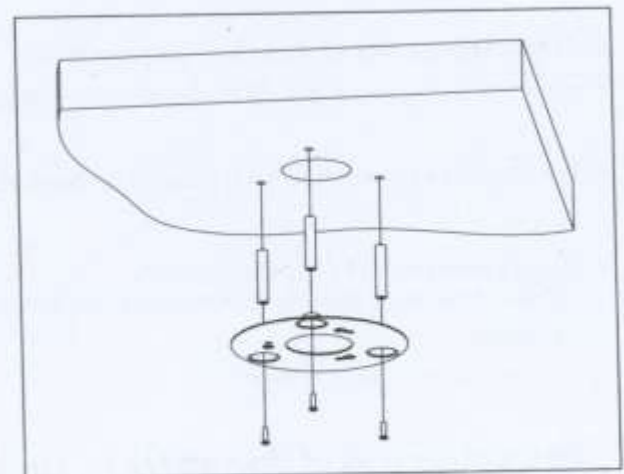

Picture 2. 1-2

3. Insert three screws in the mini dome into the apertures on the base board(pls refer to①), then turn 15 degrees in clockwise(pls refer to②).

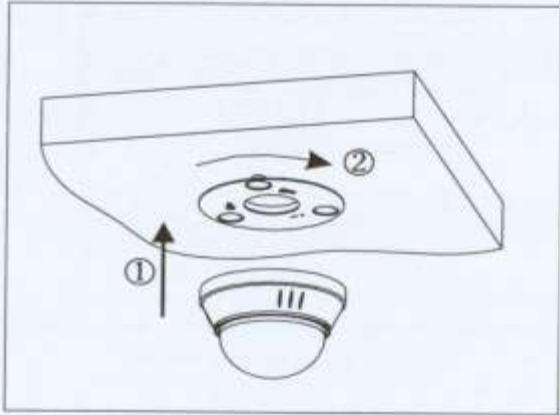

Picture2.1-3

2.2 Wall mount

1. Dimension of product as picture below

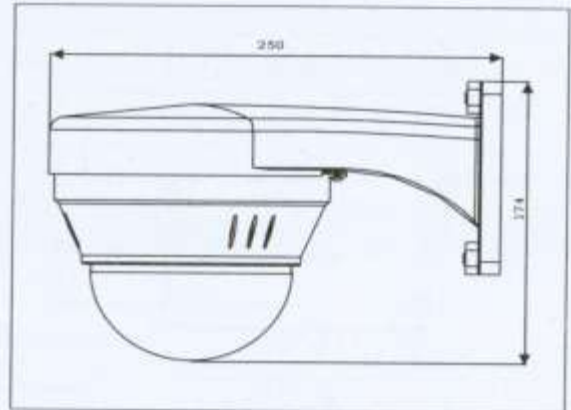

Picture 2.2

4. Using 3 additional M3*5 screws to lock tightly.

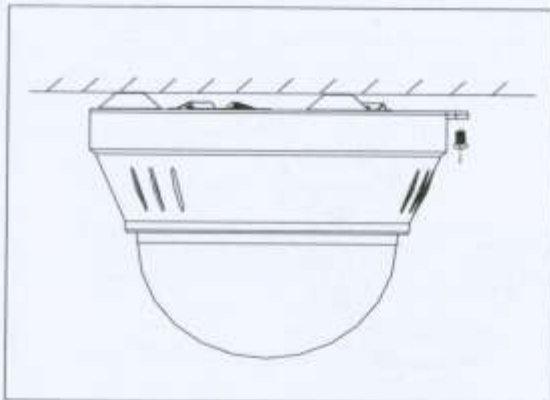

Picture 2.1-4

5. Connect the power cable, video cable and Rs485control-cable. As the picture below.

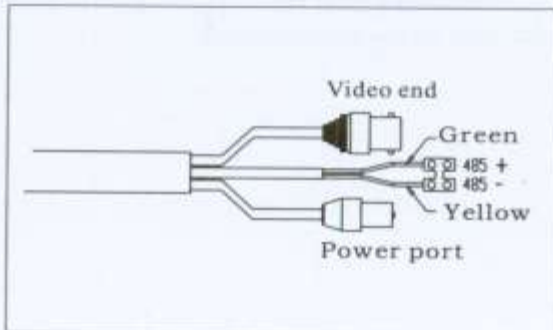

Picture 2.1-5

2. Installation of product

1. Get the products out from the packages.

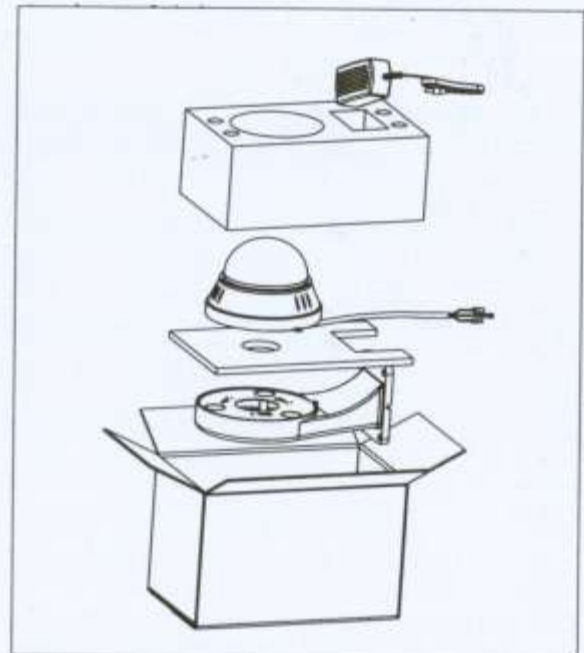

Picture 2.2-1

2. Make the wall bracket as the model on installation wall, and draw the central position of the drill hole. (As picture 2.2-2)

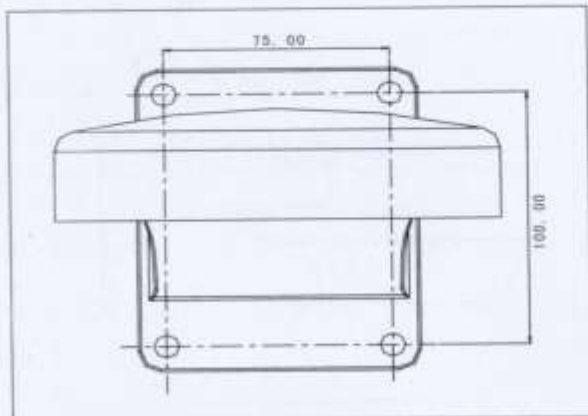

Picture2.2-2

3. Please drill four installation holes for M8 metal expand screw with the lashed electric drill on the installation surface, and be sure with the installation hole of 75mm depth approximately and M8 expand metal screw. (As picture 2.2-3)

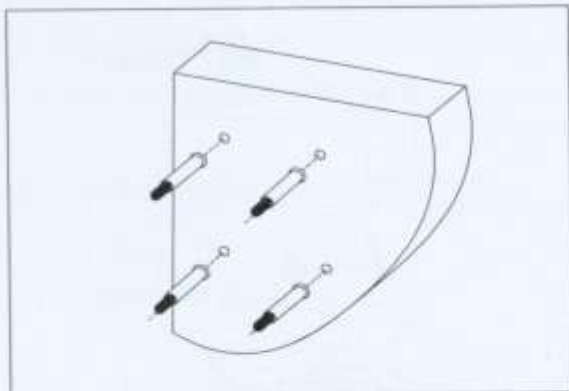

Picture2.2-3

4. Get the water-proof output cable of mini dome through the wall bracket, and make the three screw of cover board in the mini dome into the aperture on the base board, then turn 15 degrees in clockwise, and be sure that central position of the two ear holes of base board and cover board are matched, and then lock it tightly using the additional M3*5 screw.

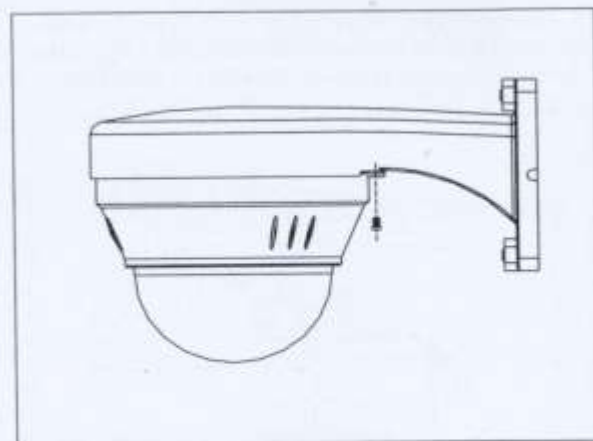

Picture2.2-4

5. Pls make the wall bracket aims at the M8 screw, so that the output cable will be locked in the hole of motherboard bracket, and use the M8 screw to lock the wall bracket tightly. As picture 2.2-5.

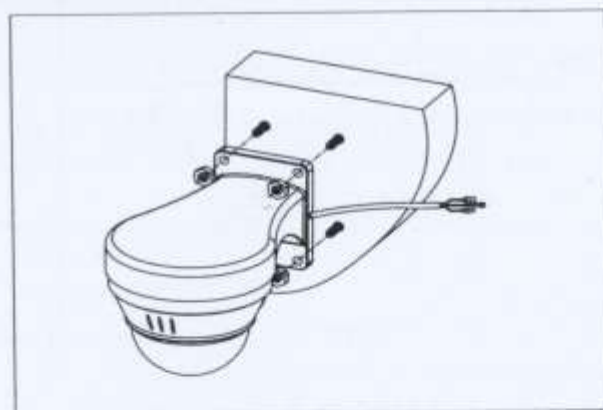

Picture2.2-5

6. Connect the power cable, video cable and Rs485 control-cable. As the picture below.

3. Dome performance

3.1 Dome parameter

Power supply		Setting	
Power supply	DC12V	Baud rate (RS485)	2400/4800/9600/19200bps
Consumption	12W	Communication Protocol	Pelco-D/Pelco-P/Samsung/ Panasonic
Operational		ID setting	0-255
Decoder	Built-in	Physical	
Pan rotation	360°	Operation temperature	-10°C — +50°C
Tilt rotation	Tilt90° , with auto-flip	Environmental humidity	0—95%(no condensation)
Rotation speed	Pan 0.5° - 160° /S Tilt 0.5° - 90° /S	Mount way	Wall mount/Ceiling
Preset	128	Wall mount	N: 2.2kg G: 2.8kg
Monitor way	Preset/ tour/ scan/ pattern	Ceiling mount	N: 1.4kg G: 1.8kg
Speed	Limitless variable-speed controlling	Material	Aluminum, iron and carbon alloy, plastic alloy

3.2 Camera parameter

Model	Specification/parameter
Imaging Element	1/4"CCD
Scanning System	625lines, 50field/s
White Balance	Auto/manual
Gain Control	Auto Gain Control
S/N	≥50dB
Shutter	Auto: 1/50-1/120,000 s continuously/manual
Lens	10 times optical magnified lens
Magnification	120times(10 times optical × 12 times digital)
Video Output	Multiple Video Output, 1.0Vp-p
Environmental Temperature	-10°C—+50°C
Environmental Humidity	0~95%(no condensation)

3.3 Dome performance and features

This product is high-technology surveillance product with high definition and color camera, variable-speed pan/tilt and multifunction decoder. It can reduce the connection and installation process between systematic parts at a max limit, and also can improve the stability and reliability of the system. Meanwhile it is easy to install and repair, and it has the following advantages: beautiful shape, rotate lightly and neatly, little noise, simple operation and so on.

1. Built-in digital camera

- High sensitivity, high resolution, and integrated digital processing
- Auto-focus
- Auto brightness control
- IR cut filter
- Auto slow shutter
- Auto-Iris
- Auto white balance
- Auto back light compensation

2. Built-in high resolution color camera with pre-focus lens.

- a. Prefocus lens 6mm, 8mm, 12mm(Optional)
- b. Auto brightness controlling
- c. Auto white balance
- d. Auto back-light compensation
- e. Auto iris
- f. Auto focus

3. Integrated and multi-protocol decoder

- a. Figure design, all the data are stored in the inner of camera pan/tilt, when power off, the storage data can't be lose.
- b. Built-in decoder. Integrated and multi-protocol, include PELCO-D, PELCO-P, SAMSUNG, PANASONIC and mainstream protocols; The protocols can automatically recognised by the dome, and which can choose corresponding protocol to communicate with host, it need not to be set by customers
- c. 128 presets can be stored, support auto tour (but only can transfer 1-80 presets), and 1 tour can store up to 32 presets.
- d. 4 pattern tour
- e. 4 scan
- f. Built-in direction indicator
- g. Built-in temperature indicator
- h. Built-in clock setting
- i. Rs485 bus controlling in series, and dome ID; 1-255 (optional)

4. Built-in pan/tilt

- ◆ Iron and carbon alloy structure, high intensity, and good heat dissipation.
- ◆ Precise stepping motor, rotate smoothly, react sensitivity and orientate accurately.
- ◆ Exquisite mechanical drive, support pan 360° continuously and tilt 0-90°, and may rotate 180° with auto flip.
- ◆ rotate slowly at pan 1° /s, and the image doesn't jitter.

5. OSD menu

- ◆ All the menu option are displayed in English.
- ◆ Video OSD menu. It is direct and simple to revise the dome information and parameter by keyboard and menu display.
- ◆ May set park action, and set power up action or arrive an appointed action.

6. Internal temperature test

- ◆ When the temperature exceeds the upper limit, the screen will display alarm information.
- ◆ According to the real-time temperature, the fan will measure if it starts or not, and prolong the life of fan.

4. Function instructure

This passage mainly describes the main function and general principle of integrated speed dome, and does not refer to the concrete operation methods. Different system platform has different operation methods, generally we should according to the system manufactory's operation manual. Please contact dealer to get necessary information, under some conditions there are have some particular requirements and operations.

4. 1 Auto-run motion

◆ Focus/speed proportion pan

When manual adjusting, for far focus situation, the dome responds at a high-speed so that touching rocker slightly may make picture move rapidly, thus cause the picture to lose. To base on humanized design, the dome automatically adjust pan and tilt rotation according to zoom near and far, which make it is convenient to operate manually to make tracks for the object. In the menu, you may change system parameter setting proportion pan as "ON", thus you may run this function.

◆ Auto flip

If user holds the joystick in the down position, the camera rotates pan 180 degrees, then the camera rotates tilts up to 90 degrees, you may directly watch the rear view to realize surveillance all processes in portrait 180 degrees. In the menu, you may set the system parameter setting AUTO FLIP as ON, thus you may run this function.

◆ Park action

By the menu " park time" and "park action", user may set auto-call preset or run tour, pattern, and scan, etc after pointing a few minutes if the dome doesn't run any motions.

◆ Power up action

By the menu " power up action", after the dome powers up or restarts, user may set auto- resume motions before power up and auto- call preset or run tour, pattern, and scan etc.

4. 2 Camera control

> Magnification control

The user can adjust zoom far and near of the image by keyboard controller "Wide/Tele" to obtain panoramic image or close view that you need. The speed dome support digital zoom and optical zoom.

> Focus control

System defaults Auto focus. When the lens changes, camera will auto-adjust focus according to the centre of the image to get legible image; user also can manually focus to get desire image by operating keyboard "FAR/NEAR". When operating keyboard joystick, camera resumes to auto focus.

The camera cannot auto focus in the following status:

- Target is not the centre of the image
- Observation the target near and far an the same time, can not be clear at the same time.
- Target is a strong light object, such as spotlight & etc.
- Target moves too fast
- Target area such as wall
- Target is too dark or vague
- Target image is too small

➤ **Iris control**

System defaults Auto Iris. Camera can rapidly adjust size of Iris, through the automatically induct the changing of environment ray, and thus make the brightness of deferent image stable.

User may adjust Iris by controller keyboard “open/close” to get required brightness that you need. User also can resume auto Iris by joystick operation. When controlling the Iris manually, the dome locks current position you manually controlled; when operating joystick, the dome resume auto Iris.

➤ **Auto back light compensation**

Camera sub-area can carry out auto back light compensation. Under a strong light background, camera will auto compensate light for the darker object and adjust daylight to the bright background. In order to avoid making the image mess by the background is too high in luminance, and the object is unable to recognize because of darkness, thus gain legible image.

➤ **Auto white balance**

Camera can automatically adjust white balance in accordance with the alteration of background lightness to reach a true colour.

4. 3 Monitor function

◆ **Set and call preset**

Preset function is that dome stores the horizontal angle, slope angle, camera lens focus position and parameters of current pan/tilt into the memory. When necessary, dome can call these parameters, and adjust pan/tilt and camera to this position.

User can call presets easily and promptly by using keyboard controlling. The dome can support 128 presets.

◆ **Tour**

Tour is the built-in function in the speed dome. It can appoint setting in advance, and make presets arranged in needful order in tour dwell. By inserting presets in tour dwell, to make the camera tour between these presets. Tour order can be programmed, each time you run tour, you can set park time. A tour can store 32 presets.

◆ **Scan**

User can easily preset right limit and left limit by controlling menu and menu, in order to make the camera scanned between right limit and left limit at a setting speed.

◆ **Pattern**

Pattern is built-in function in the speed dome; the dome can record the tracks that are no less than 180s, when running pattern, the dome moves repeatedly according to the recorded tracks. A dome can set up to 4 pattern tours.

◆ **Lens position display**

The position that the speed dome has finished to self-testing as 0 point of pan rotation and tilt rotation. The pan range is 0-360° , and tilt range is 0-90° . According to the displayed information, to set the position of camera lens, and the position can display on the screen.

4. 4 Constant temperature Function

Inner temperature sensor check temperature inside of the dome. When the dome work at the high temperature, the dome will automatically to start-up the fan to reduce the heat, to make sure the dome work in the reliable temperature environment, increase its stability and prolong the life time of the dome.

5. System setting

5.1 Basic operation

5.1.1 Current-carrying to dome and self-testing

The dome conducts self-testing after current-carrying, and it rotates slowly until displaying pan origin that is default setting, then moving to tilt origin, the lens will be pulled far to near and near to far, when self-testing is finished, there is relevant system information displaying on the screen, as follow:

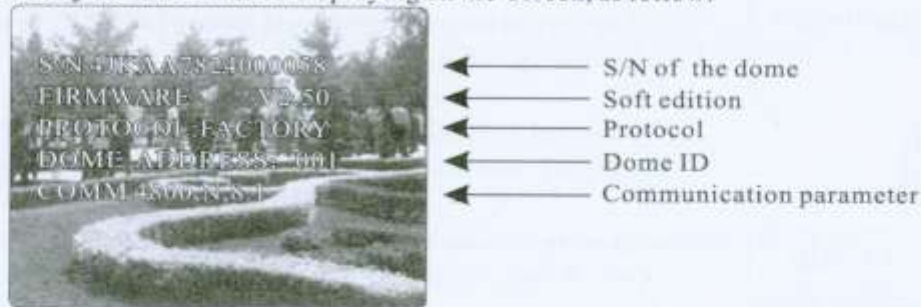

The information will not disappear until you stop to operate the system. If you set "power up action", the dome will automatically activate motions after self-testing. How to operate the function? We will explain detail introduction in following passages.

5.1.2 Call the main menu

The system enters into the main menu by 95 preset or twice transfer 9 preset within 3 seconds. All the menu setting must enter into the main menu at first. You need input password when you sign in the menu if you set up password and have a super-password for the time of forget the password (super-password "892226"), then the password will turn to factory setting (original password "000000"). You need set the password again if you need it, the detail of information show in password setting 4.7.

5.1.3 Menu and keyboard operation

> Keyboard operation:

【OPEN】 when choosing pictures, it means to increase Iris; when setting menu, it means to enter into the next menu or setting, or save after finishing setting.

【Close】 when choosing pictures, it means to reduce Iris; close to cancel.

【FAR】 Focus to far

【NEAR】 Focus to near

【TELE】 Increase magnification

【WIDE】 Reduce magnification

Joystick to up: When choosing menu, it means to choose the former one; when choosing picture, it means camera tilt up.

Joystick to down: when choosing menu, it means to choose the next one; when choosing picture, it means camera tilt down.

Joystick to left: when choosing menu, it is equal with **【Close】**, when choosing picture, it means camera tilt left.

Joystick to right: when choosing menu, it is equal with **【Open】**, when choosing picture, it means camera tilt right.

Press **【TELE】** and **【WIDE】** at the same time, it means 3D joystick rotates joystick cap.

> Menu operation

"Back" : Back to the former menu

"Exit" : Exit to menu

"On" : Open some setting

"Off" : close some setting

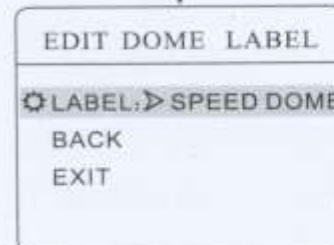
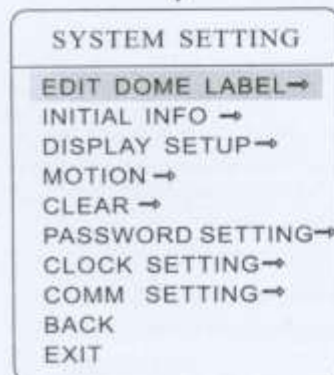
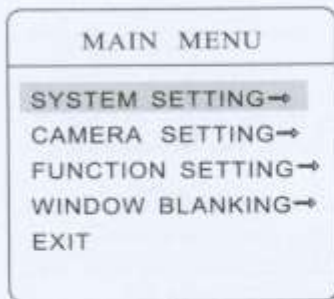

5. 2 Edit dome label

When using a lot of systems of the dome , in order to identify each dome, the systems support title setting. The setting ways as follow:

1. The system enters into the main menu by calling 95 preset or by calling 9 preset twice within 3 seconds.
2. Moving joystick up and down to move the cursor to **【SYSTEM SETTING】** ,and pressing **【OPEN】** to enter the next menu.
3. Moving joystick up and down to move the cursor to **【EDIT DOME LABEL】** ,and pressing **【OPEN】** to enter the label setting menu.
4. Moving joystick up and down to move the cursor to **【LABEL】** , pressing **【OPEN】** to edit current label.
5. When the cursor is twinkling in the first character of the label, to move joystick to choose character, after editing, Pressing **【OPEN】** to save.
6. Moving joystick to **【BACK】** ,press **【OPEN】** to back to the former menu.



Notice: The label may set 16 characters, and doesn't need editing characters. Pressing **【OPEN】** continuously to jump over and using spacebar to replace the deleted characters. When you finish to edit a character,pressing **【OPEN】** to enter into the next editing character, when you editing the last character, pressing **【OPEN】** to save. Press **【CLOSE】** to exit.

Character of label is suitable for choosing as follow:0-9、 A-Z、 :<>-.,Space.Other labels' input ways are the same as above.

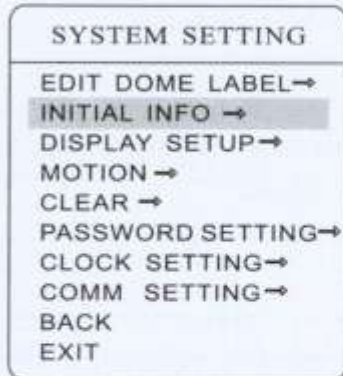
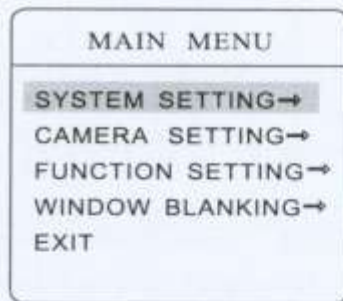

5. 3 Display initial information

1. The system enters into the main menu by calling 95 preset or by calling 9 preset twice within 3 seconds.
2. Tilt up/down joystick to **【SYSTEM SETTING】** ,press **【OPEN】** to enter submenu.
3. Tilt up/down joystick to **【INITIAL INFO】** ,press **【OPEN】** to display initial information which as below the left picture shows:

Initial information includes S/N of the dome, the name of manufacturer, soft edition, camera address, communication parameter. System setting may change the numerical value of initial information.

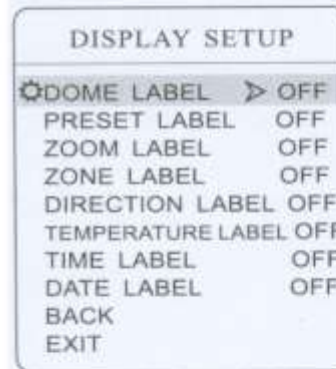
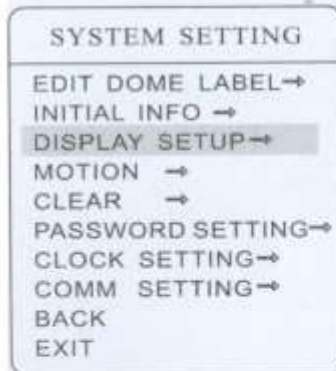
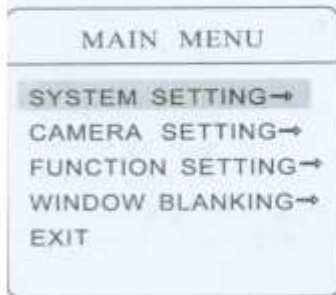

5. 4 Display setup

1. The system enters into the main menu by calling 95 preset or by calling 9 preset twice within 3 seconds.
2. Tilt up/down joystick to **【SYSTEM SETTING】** , press **【OPEN】** to enter submenu.
3. Tilt up/down joystick to **【DISPLAY SETUP】** , press **【OPEN】** to enter display setup menu, may setting the content of the display setup as follow:

- **【DOME LABEL】** : dome label display setting
- **【PRESET LABEL】** : preset label or scan label display setting
- **【ZOOM LABEL】** : magnification display setting
- **【ZONE LABEL】** : zone label display setting
- **【DIRECTION LABEL】** : direction label display setting
- **【TEMPERATURE LABEL】** : temperature label display setting
- **【TIME LABEL】** : time label display setting
- **【DATE LABEL】** : date label display setting

4. Taking “display dome label” as an example to explain the operation process. Tilt up/down joystick to move cursor to **【DOME LABEL OFF】** , press **【OPEN】** , there is a sign  besides **【DOME LABEL】** , the cursor is twinkling besides **【OFF】** , as left picture shows.

5. Joystick tilts up/down, setting switch between ON/OFF, when displaying **【ON】** , it means to display dome label, press **【OPEN】** , the cursor jump back to **【DOME LABEL】** , label setting is finished, move the cursor to **【EXIT】** , exit to the menu setting.

The display information on the screen will change with the dome rotation through the information on the screen, user can see current dome inside temperature, magnification, display zone etc. When all the labels are displayed, the dome works as the following picture shows: (in the picture “305” means pan angel, “45” means tilt angle.)



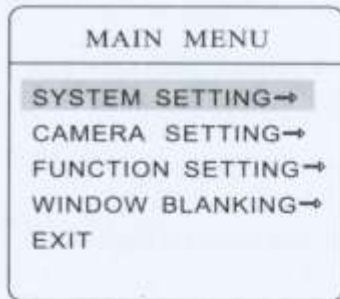

5. 5 Systematic motion control

Systematic motion controlling may control a series of canonical movement of the dome, and plays an important role in controlling the image of the dome.

1. The system enters into the main menu by calling 95 preset or by calling 9 preset twice within 3 seconds.
2. Tilt up/down joystick to **【SYSTEM SETTING】** , press **【OPEN】** to enter submenu.
3. Tilt up/down joystick to **【MOTION】** , press **【OPEN】** to enter systematic motion controlling menu, as left picture shows.

5. 5. 1 Auto flip

1. Operate joystick, move the cursor to **【AUTO FLIP】** ; press **【OPEN】** to enter " auto flip " setting, tilt up/down joystick, for example: choosing ON to open " auto flip " ; choosing OFF to close "auto flip" . Press **【OPEN】** to save.

OPERATION KNACKS

When opening the auto flip function, user holds the joystick in the down position, the camera rotates pan 180 degrees, after the camera rotates tilts up to 90 degrees, you may directly watch the rear view to surveillance all processes in portrait 180 degrees .

5. 5. 2 Speed proportion pan

- Operate joystick, move the cursor to **【PROPORTIONAL PAN】** ; press **【OPEN】** to enter " proportion pan " setting, tilt up/down joystick to choose, if choosing **【ON】** , it means to open proportion pan; if choosing **【OFF】** , it means to close proportion pan , press **【OPEN】** to save.

OPERATION KNACKS

When manually adjusting, for far focus situation, the dome responds at a high-speed so that touching rocker slightly may make picture move rapidly, thus cause the picture to lose. To base on humanized design, the dome automatically adjust pan and tilt rotation according to zoom near and far, which make it is convenient to operate manually run after object.

MOTION	
AUTO FLIP	ON
PROPORTION PAN	ON
⊗PARK TIME	➤ 005
PARK ACTION	SCAN
POWER UP ACTION	AUTO
FAN ENABLED	040
TEMP C/F	CENT
HEAD-UP	OFF
BACK	
EXIT	

MOTION	
AUTO FLIP	ON
PROPORTION PAN	ON
PARK TIME	005
PARK ACTION	SCAN
⊗POWER UP ACTION	➤ AUTO
FAN ENABLED	040
TEMP C/F	CENT
HEAD-UP	OFF
BACK	
EXIT	

MOTION	
AUTO FLIP	ON
PROPORTION PAN	ON
PARK TIME	005
PARK ACTION	SCAN
POWER UP ACTION	AUTO
⊗FAN ENABLED	➤ 040
TEMP C/F	CENT
HEAD-UP	OFF
BACK	
EXIT	

5. 5. 3 Park action

This setting allows the dome to run an appointed action after it enters vacancy for a few time (1-240minutes). If default sets as 0, it means not to run this action.

- Operate joystick, move the cursor to **【PARK TIME】**, press **【OPEN】** to tilt up/down joystick to set park time, the range is 0-240 (minute), press **【OPEN】** to save. **【PARK ACTION】** is running action at park time, when **【PARK TIME】** sets as 0, this item can't be set.
- Operate joystick, move the cursor to **【PARK ACTION】**, press **【OPEN】** there will be a sign ⊗ in the front of **【PARK ACTION】**, the cursor jump to right, after tilting up/down joystick to choose "park action", there are options for choosing as follow, press **【OPEN】** to save.

- **【NONE】** - (default) none action
- **【PRESET】** -use preset 1
- **【SCAN】** -run scan
- **【PAT1】** - run pattern X
- **【TOUR】** - run tour

5. 5. 4 Power up action

The dome startup to run actions after self-testing, if nobody intervenes with it, the dome will repeatedly run this action continuously, if default sets as **【NONE】**.

- Operate joystick, move the cursor to **【POWER UP ACTION】**: press **【OPEN】** to jump to the following choice, tilt up/down joystick to choose "power up action", press **【OPEN】** to save.

- **【NONE】** - none action
- **【AUTO】** - the dome resumes the primary action and direction before power up.
- **【PRESET】** - use preset 1
- **【SCAN】** - run scan
- **【PAT1】** - run pattern X
- **【TOUR】** - run tour

5. 5. 5 Fan startup by temperature

The temperature of the dome will rise when its environment is in high temperature. The fan will open automatically when the temperature reaches to a temperature value in order to make sure the stability of the dome.

Operate joystick, move the cursor to **【FAN ENABLED】**: press **【OPEN】**, the cursor will skip to the back option. The user can press **【OPEN】** to save it in actual condition.

The default setting temperature of the fan startup is 40°C. The user also can enter into the fan startup setting to adjust the temperature of fan startup. As picture shows: the temperature range is 0-60°C.

【TEMP】 can switch temperature between fahrenheit and centigrade

5. 5. 6 Head-up mounting setting

"ON" means "Head" monut;

"OFF" means "Head-up" monut.

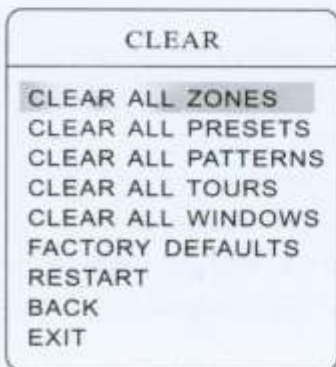
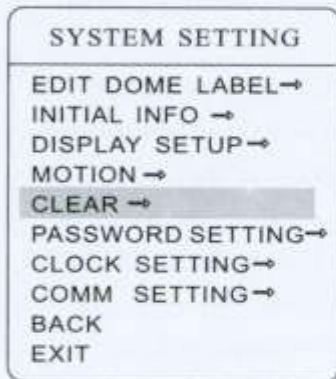
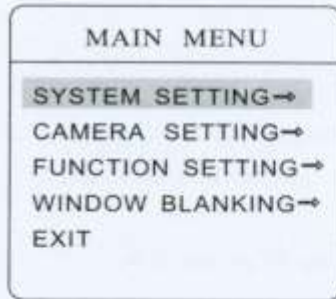

5.6 Clear

1. The system enters into the main menu by calling 95 preset or by calling 9 preset twice within 3 seconds.

2. Operate joystick, move the cursor to **【SYSTEM SETTING】**, press **【OPEN】** to enter submenu.

3. Operate joystick, move the cursor to **【CLEAR】**, press **【OPEN】** to enter submenu, as left picture shows.

- **【CLEAR ALL ZONES】**
- **【CLEAR ALL PRESETS】**
- **【CLEAR ALL PATTERNS】**
- **【CLEAR ALL TOURS】**
- **【CLEAR ALL WINDOWS】**
- **【FACTORY DEFAULTS】**: resume the Factory default. Run this function, the camera parameter and system parameter will resume to the initialized state, and clear all windows and alarm setting. So please be cautious to use this function.

- **【RESTART】**

4. Set clear zone as an example to explain the process. Tilt up/down joystick to **【CLEAR ALL ZONES】**, press **【OPEN】** to clear all zones.



NOTICE

Once clear all commands in the controlling menu they does not resume, so please be careful of using.

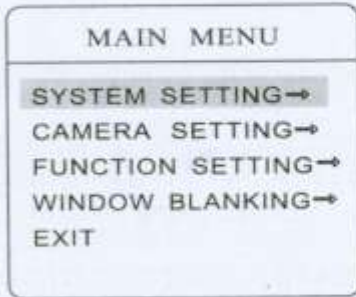

5. 7 Password Setting

Password setting is the built-in function of high speed dome, By setting password (6 bits) it is very useful to protect the dome setting, if no password, you can't enter the setting menu. the initial password of the dome is "000000".

- 1.The system enters into the main menu by calling 95 preset or by calling 9 preset twice within 3 seconds.
- 2.Tilt up and down the joystick and move the cursor to **【SYSTEM SETTING】** , press **【OPEN】** to call the submenu.
- 3.Tilt up and down the joystick and move the cursor to **【PASSWORD SETTING】** , press **【OPEN】** to call System motion controlling menu, as the left picture shows.
- 4.Input old password: Operate joystick, move the cursor to **【OLD PASSWORD】** , press **【OPEN】** , there will be a sign  to display in the front of **【OLD PASSWORD】** , the cursor jumps to the first character on the right, tilt up and down the joystick to set the first password, its option rage is 0-9, by tilting left and right the joystick to input the other bits, press **【OPEN】** to save.
- 5.Input new password: Operate joystick, move the cursor to **【NEW PASSWORD】** , press **【OPEN】** , there will be a sign  to display in the front of **【NEW PASSWORD】** , the cursor jumps to the first character on the right, according to the above instruction user can ordinarily input the password by tilting up/down joystick, press **【OPEN】** to over.
6. Confirm the new password: Input the user's needful password again according to above method. Failing to modify the password if inputted password is different with the fifth step.
7. Start password or not: operate joystick, move cursor to **【ENABLE PASSWORD】** . Pressing **【OPEN】** , moving joystick up and down, switch setup value between ON/OFF, show **【ON】** , means the setting password is valid, show **【OFF】** , means the setting password is invalid.



Notice:

While user forgot password, and can't enter into main menu, user can use super password, PTZ's password will be changed as initial one, at this time User need to reset the password. PTZ's initial password is 000000, Super password is 892226

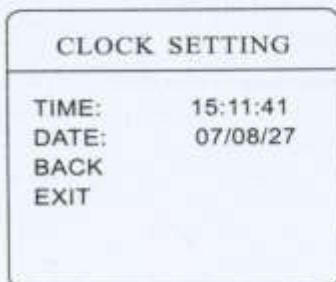
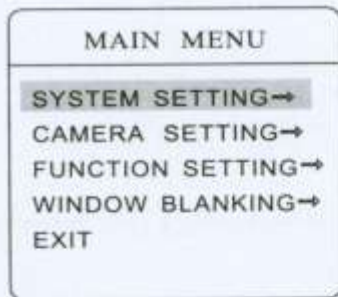

5. 8 Date and clock setting

1.The system enters into the main menu by calling 95 preset or by calling 9 preset twice within 3 second.

2.Move the cursor to **【System setting】** by up and down the joystick, press **【OPEN】** to enter into the next menu

3.move the cursor to **【Clock setting】** by up and down the joystick. Press **【OPEN】** to call clock setting, you could set the following

- **【TIME】**
- **【DATE】**

4. For example. move the cursor to **【TIME】** by up and down the joystick, press **【OPEN】** . Pls move the cursor to the first number (the three number means hour, minute, second, it also means year, month, date under the **【DATE】** . Setting the [Hour] by tilt up\down the joystick. Setting the **【MINUTE】** 、 **【SECOND】** by turning right and left the joystick. Press **【OPEN】** to save.

MAIN MENU
SYSTEM SETTING→
CAMERA SETTING→
FUNCTION SETTING→
WINDOW BLANKING→
EXIT

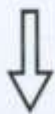

SYSTEM SETTING
EDIT DOME LABEL→
INITIAL INFO →
DISPLAY SETUP→
MOTION →
CLEAR →
PASSWORD SETTING→
CLOCK SETTING→
COMM SETTING→
BACK
EXIT



COMM SETTING
S/N: 4JCAA7824000058
CONF: 4JCAA7824000058
SITE ID 001
COMM SPEED 4800BPS
PROTOCOL VIDO B02
BACK
EXIT

5.9 COMM Setting

1. The system enters into the main menu by calling 95 preset or by calling 9 preset twice within 3 second.
2. Operate joystick, move the cursor to **【SYSTEM SETTING】**, and pressing **【OPEN】** to enter into the next menu.
3. Operate joystick, move the cursor to **【COMM SETTING】**, and pressing **【OPEN】** to enter into Dome parameter setup menu.

S/N: Show Series NO. of the dome ex-work.

CONF: Using to edit, the series NO. of the dome is the same as S/N series Numer.

SITE ID: Setting up the ID Number of the dome, address scope (001-255).

COMM SPEED: Baud rate setup. The user can choose 4 kinds of Baud rate (2400 BPS, 4800 BPS, 9600 BPS, 19200 BPS).

PROTOCOL: set protocol, the user can choose 16 kinds of protocol: PELCO, FACTORY, DYNACOLOR, ISD, HUNDA, VIDO B02, LILIN, KALATEL, DIAMOND, SAMSUNG, PANASONIC, SANTACHI, VICON, MOLYNX, VCL、SAE.



NOTICE

1. below operation can not be continue when above two series Number are not the same.
2. The setting is effective while restart the dome after finishing dome parameter setting

6. Camera setting

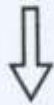
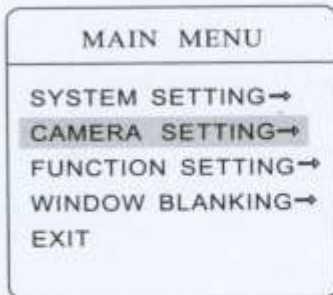

6. 1 Zoom speed

1. The system enters into the main menu by calling 95 preset or by calling 9 preset twice within 3 seconds.
2. Tilt up/down joystick to **【CAMERA SETTING】** , press **【OPEN】** to enter submenu.
3. Operate joystick, move the cursor to **【ZOOM SPEED】** ; press **【OPEN】** will appear a sign ⚙️ in the front of **【ZOOM SPEED】** , the cursor moves to right, tilt up/down joystick to choose **【HIGH】** or **【LOW】** .
4. Press **【OPEN】** to save, press **【CLOSE】** to cancel.

MAIN MENU	
SYSTEM SETTING→	
CAMERA SETTING→	
FUNCTION SETTING→	
WINDOW BLANKING→	
EXIT	



CAMERA SETTING	
ZOOM SPEED	HIGH
⚙️ DIGITAL ZOOM	▷ ON
BLC MODE	OFF
SLOW SHUTTER	X2
IR CUT FILTER →	
ADVANCE SETTING→	
BACK	
EXIT	

6. 2 Digital zoom control

- 1、 The system enters into the main menu by calling 95 preset or by calling 9 preset twice within 3 seconds.
- 2、 Tilt up/down joystick to **【CAMERA SETTING】** , press **【OPEN】** to enter camera setting.
- 3、 Operate joystick, move the cursor to **【DIGITAL ZOOM】** , press **【OPEN】** to enter digital zoom setting, tilt up/down joystick, to choose ON means open digital zoom control which is digital zoom is pulled near, if pulling the digital zoom near again, the dome enters into “ digital zoom increase” ; to choose OFF means to close digital zoom control.
- 4、 Press **【OPEN】** to save.

OPERATION KNACKS

When digital zoom be set as ON, the maximum zoom magnification of the dome is digital zoom magnification times optical zoom magnification; when digital zoom be set as OFF, the maximum zoom magnification of the dome is optical zoom magnification.

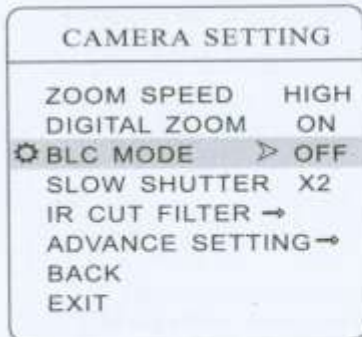
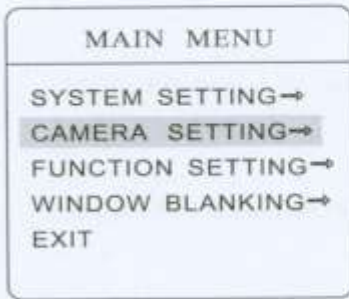

6. 3 Back light compensation

1. The system enters into the main menu by calling 95 preset or by calling 9 preset twice within 3 seconds.
2. Operate joystick, move the cursor to **【CAMERA SETTING】** to enter submenu.
3. Operate joystick, move the cursor to **【BLC MODE】**, press **【OPEN】**, There will be a sign ⚙️ in the front of **【BLC MODE】**, the cursor jump to right, tilt joystick to open or close back light compensation function. If choosing ON means to open back light compensation mode; if choosing OFF means to close back light compensation mode;
4. Press **【OPEN】** to save.

OPERATION KNACKS

Strong background ray can make backlighting objects engender shadow, (back light compensation), the speed dome can auto-adjust iris to match with the changes of various ray, and auto-revise the main lightness to make the pictures more legible.



NOTICE

This function relates to models and parameters of the built-in camera in the dome, when open black compensation, it has two functions which are auto-adjust (when you choose ON)



Non-use back light compensation, in strong sunshine, the back light side is subject to dark.



Use back light compensation, the image is in gear.

MAIN MENU	
SYSTEM SETTING→	
CAMERA SETTING→	
FUNCTION SETTING→	
WINDOW BLANKING→	
EXIT	



CAMERA SETTING	
ZOOM SPEED	HIGH
DIGITAL ZOOM	ON
BLC MODE	OFF
⚙ SLOW SHUTTER▷X2	
IR CUT FILTER →	
ADVANCE SETTING→	
BACK	
EXIT	

6. 4 Slow shutter control

1. The system enters into the main menu by calling 95 preset or by calling 9 preset twice within 3 seconds.
2. Operate joystick, move the cursor to **【CAMERA SETTING】** to enter submenu.
3. Operate joystick , move the cursor to [SLOW SHUTTER], press[OPEN], then there will have a sign ⚙ in the front of [SLOW SHUTTER], The cursor moves to right, you can make your choice when tilt up/down joystick. (Can choose from X2、X4、X6、X8、X10、X12、X14、X16、X24、X32、X64、X128, which according to the time of lighting in turn, the more the long lighting).
4. Press **【OPEN】** to save.

OPERATION KNACKS

When the dome monitors at night or dark environment, because the ray is not enough, the image on the screen is too dark, setting slow shutter can lengthen the time of lighting so that make the picture that is shoot in dark more legible.

MAIN MENU	
SYSTEM SETTING→	
CAMERA SETTING→	
FUNCTION SETTING→	
WINDOW BLANKING→	
EXIT	



CAMERA SETTING	
ZOOM SPEED	HIGH
DIGITAL ZOOM	ON
BLC MODE	OFF
SLOW SHUTTER	X2
IR CUT FILTER →	
ADVANCE SETTING→	
BACK	
EXIT	

IR CUT FILTER	
IR CUT FILTER	AUTO
IR CUT ON TIME	N/A
IR CUT OFF TIME	N/A
BACK	
EXIT	

6. 5 IR cut filter

1. The system enters into the main menu by calling 95 preset or by calling 9 preset twice within 3 seconds.

2. Operate joystick, move the cursor to **【CAMERA SETTING】** to enter submenu.

3. Operate joystick, move the cursor to **【IR CUT FILTER】**; press **【OPEN】**, there will be a sign  in the front of **【IR CUT FILTER】**, the cursor jumps to right, move joystick to "IR cut filter", choices as follow, **【AUTO】** is default.

- **【AUTO】** IR cut filter mode, it means the dome automatically transfers according to sensitivity.
- **【TIME】** Can set black/color time; for example, can set color image in day and set black in the night; it is valid to set time under time mode, but invalid under other mode.
- **【COLOR】** set as color mode
- **【BLACK】** set as black and white mode

4. Press **【OPEN】** to save.

OPERATION KNACKS

IR cut filter function uses color in day; use black and white at night. This function not only guarantees the quality of image, but also saves the room of storage.



NOTICE

This function depends on the models and parameters of built-in camera in dome, if the camera haven't this function, then this function is invalid.(N/A)

MAIN MENU

SYSTEM SETTING→
CAMERA SETTING→
 FUNCTION SETTING→
 WINDOW BLANKING→
 EXIT



CAMERA SETTING

ZOOM SPEED HIGH
 DIGITAL ZOOM ON
 BLC MODE OFF
 SLOW SHUTTER X2
 IR CUT FILTER →
ADVANCE SETTING→
 BACK
 EXIT

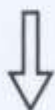

ADVANCE SETTING

AE MODE	AUTO
SHUTTER	N/A
IRIS	N/A
BRIGHT	N/A
WB MODE	AUTO
R GAIN	N/A
B GAIN	N/A
ENTER CAMERA MENU	
BACK	
EXIT	

5. 6 Advance setting

1. The system enters into the main menu by calling 95 preset or by calling 9 preset twice within 3 seconds.
2. Operate joystick, move the cursor to **【CAMERA SETTING】** to enter submenu.
3. Operate joystick, move the cursor to **【ADVANCE SETTING】**; press **【OPEN】** to enter submenu, as left picture shows;

5. 6. 1 AE mode

1. Operate joystick, move the cursor to **【AE MODE】**, press **【OPEN】**, tilt up/down joystick to choose AE mode, modes for choosing as follow:
 - **【AUTO】**: default setting, auto Iris mode
 - **【BRIGHT】**: brightness priority mode
 - **【IRIS】**: iris priority mode
 - **【SHUTTER】**: shutter priority mode
2. Choose Iris priority mode **【IRIS】**, press **【OPEN】** to save.
3. Move joystick to the sub-choices of AE mode **【IRIS F1.4】**, press **【OPEN】** to choose adequate Iris, press **【OPEN】** to save.
 - **【SHUTTER 1/50】** it means shutter speed, when AE mode is shutter priority, this function can be set.
 - **【IRIS F1.4】** it means the size of iris, when AE mode is iris priority, this function can be set.
 - **【BRIGHT F2.0/ODB】** it means brightness, when AE mode is brightness priority, this function can be set.

OPERATION KNACKS

Quality of Image relates to exposure amount, that is to say how much light can make CCD receives legible image. Exposure amount is relative to the time of lighten (be up to shutter speed) and the area of lighten (be up to the size of iris).

The camera can automatically calculate suitable exposure amount according to brightness of scenery and CCD sensitivity, in the situation that the exposure amount is certain: **【SHUTTER】** (shutter priority) is to fix shutter speed, the camera will auto decide to use how much iris; **【IRIS】** (iris priority) is to fix the size of iris, and auto-decide to use shutter speed. **【BRIGHT】** (brightness priority) is point that the camera TTL check the light directly and control the brightness of image.

MAIN MENU	
SYSTEM SETTING→	
CAMERA SETTING→	
FUNCTION SETTING→	
WINDOW BLANKING→	
EXIT	



CAMERA SETTING	
ZOOM SPEED	HIGH
DIGITAL ZOOM	ON
BLC MODE	OFF
SLOW SHUTTER	X2
IR CUT FILTER →	
ADVANCE SETTING→	
BACK	
EXIT	



ADVANCE SETTING	
AE MODE	AUTO
SHUTTER	N/A
IRIS	N/A
BRIGHT	N/A
WB MODE	AUTO
R GAIN	N/A
B GAIN	N/A
ENTER CAMERA MENU	
BACK	
EXIT	

ADVANCE SETTING	
AE MODE	AUTO
SHUTTER	N/A
IRIS	N/A
BRIGHT	N/A
WB MODE	AUTO
R GAIN	N/A
B GAIN	N/A
ENTER CAMERA MENU	
BACK	
EXIT	

6. 6. 2 White balance mode

System supports **【AUTO】**、indoor mode **【INDOOR】**、outdoor mode **【OUTDOOR】**、auto track mode **【ATW】**、single mode **【OPW】**、**【OPT】** mode、manual mode **【MANUAL】** and kinds of white balance modes, etc. Detail setting as follow:

1、The system enters into the main menu by calling 95 preset or by calling 9 preset twice within 3 seconds. click each command enter into “ advanced setting” menu according to the order in left picture .

2、Operate joystick, move the cursor to **【WB MODE】** to choose white balance mode, press **【OPEN】** to save.

Auto mode **【AUTO】** is the default mode of speed dome, which is auto-revert real color after the white balance sensor check the environment by camera. When choosing manual mode **【MANUAL】** , adjust the numerical value of **【R GAIN】** and **【B GAIN】** .

- **【R GAIN】** the range is 1-225; the numerical value is bigger, it means that adding red is more, the tone changes to be warm.
- **【B GAIN】** the range is 1-225; the numerical value is bigger, it means that adding green is more, the tone changes to be cold.

6. 6. 3 Camera menu setting

1、Operate joystick, move the cursor to **【ENTER CAMERA MENU】** , press **【OPEN】** to enter into camera menu setting.



NOTICE That means the current camera has no such function when the setting option shows N/A.

7. Function setting

7.1 Preset setting

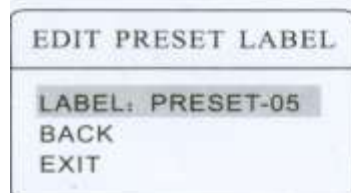
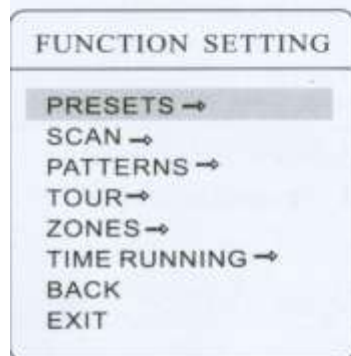
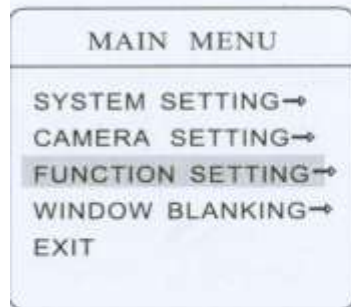

1. The system enters into the main menu by calling 95 preset or by calling 9 preset twice within 3 seconds. click each command to enter “ preset menu” according to the order of the left picture. As following:

- **【PRESET NUMBER】** select preset number as current preset
- **【SET PRESET】**
- **【SHOW PRESET】**
- **【CLEAR PRESET】**
- **【EDIT PRESET LABEL】**

Define preset and call preset function can be set by keyboard operation, input preset number at first, then click the key “ save reset/call preset” to carry out.

2. Define current preset number: move the cursor to **【PRESET NUMBER】** ,press **【OPEN】** to choose preset number, the range is 01-128, as the left picture shows, here chooses number 5 as current preset, the following operations aim at the current preset.

3. Define current preset: move the cursor to **【SET PRESET】** , press **【OPEN】** , by operating joystick to adjust magnification, to choose good objective image, press **【OPEN】** to save. If the image is very near, the image is belong in digital zoom; when setting preset, the image will jump to maximal optical zoom.



Operation knacks:

Preset function is that dome stores current pan/tilt angle, zoom and other position parameters into the memory. When necessary dome recalls these parameters and adjust camera to that position.

4. Display current preset: move the cursor to **【SHOW PRESET】** , press **【OPEN】** , the screen will display the current preset;

5. Clear current preset: move the cursor to **【CLEAR PRESET】** , press **【OPEN】** , the current preset is cleared.

6. Edit current preset label: move the cursor to **【EDIT PRESET LABEL】** , press **【OPEN】** to enter into editing preset submenu, system auto-sets label as PRESET-XX, press **【OPEN】** to revise label.

Notice:

1. When running to program, display, clear preset and edit label, should choose preset number at first.
2. The label may set up to 16 characters, and doesn't need editing characters. Press **【Open】** continuously to jump over and ues spacebar to replace the deleted characters. When you finish to edit a character, press **【Open】** to enter into the next editing character; when you finish to edit the last character, pressing **【Open】** to save. Press **【Close】** to exit.



Character of label is suitable for choosing as follow: 0-9, A-Z, :<->, space.

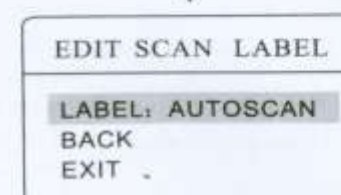
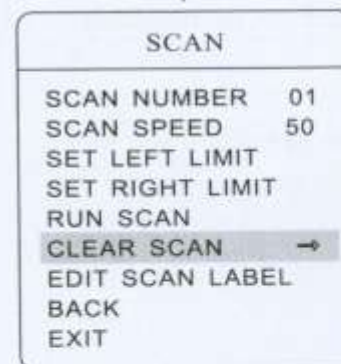
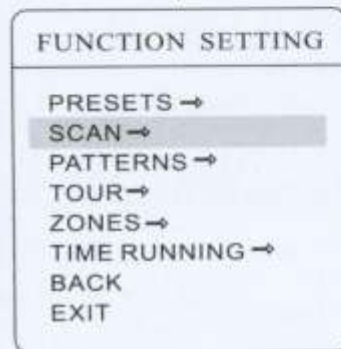
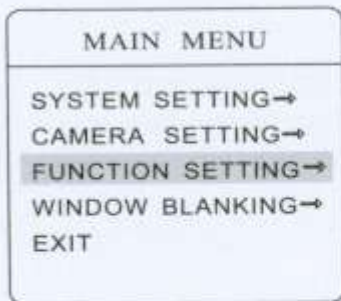

7. 2 Scan

Scan is that pre-set two points , then the camera repeatedly scan between the two points at a stable speed, the same magnification and pan . A dome only has four scan tour.

1. The system enters into the main menu by calling 95 preset or by calling 9 preset twice within 3 seconds. click menu to enter "scan" menu, as the left picture shows.

- **【SCAN NUMBER】**
- **【SCAN SPEED】**
- **【SET LEFT LIMIT】**
- **【SET RIGHT LIMIT】**
- **【RUN SCAN】**
- **【CLEAR SCAN】**
- **【EDIT SCAN LABEL】**

2. Scan speed setting: operate joystick to **【SCAN SPEED】** , press **【OPEN】**, tilt up/down joystick to adjust scan speed, press **【OPEN】** to save.

3. Left limit setting: operate joystick to **【SET LEFT LIMIT】** , press **【OPEN】**, operate joystick to choose objective image, press **【OPEN】** to save.

4. Edit scan label: operate joystick, move the cursor to **【EDIT SCAN LABEL】** , press **【OPEN】** to enter submenu " edit label" , move the cursor to **【LABEL】** , the system will auto-set the label as AUTO SCAN, press **【OPEN】** to revise.

 **Notice:** The label can set up to 16 characters, and doesn't need editing characters. Pressing **【Open】** continuously to jump over and using spacebar to replace the deleted characters. When you finish to edit a character, pressing **【Open】** to enter into the next editing character; when you finish to edit the last character, pressing **【Open】** to save. Press **【Close】** to exit.

Character of label is suitable for choosing as follow: 0-9、 A-Z、 :<>、. , space. The editing ways of other labels are the same as above.

5. Run scan: operate joystick to **【RUN SCAN】** , press **【OPEN】** to exit the menu, and it starts to run scan.

 **Notice:** 1. left limit and right limit of scan can't be set the same point. 2. Under scan process, speed, magnification and tilt direction won't change, if the speed, magnification and tilt direction of the two limits are inconsistent, run scan is base on left limit.

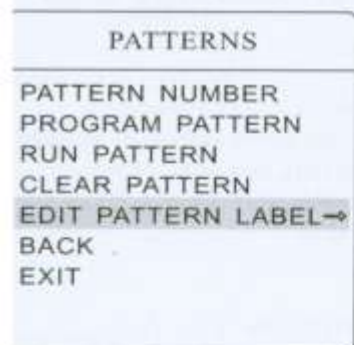
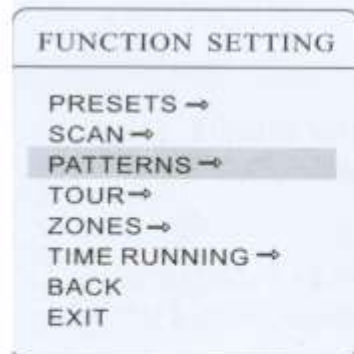

7.3 Pattern

Pattern is built-in function in camera; the speed dome can record tracks that are not less than 180s. (A series of pan/tilt controlling and lens controlling command). A dome may set up to 4 pattern tours.

1. The system enters into the main menu by calling 95 preset or by calling 9 preset twice within 3 seconds.

2. Operate joystick, move the cursor to **【FUNCTION SETTING】**, press **【OPEN】** to enter submenu.

3. Operate joystick to **【PATTERN】**, press **【OPEN】** to enter menu "Pattern".

- **【PATTERN NUMBER】** choose current pattern number as the current pattern.
- **【PROGRAM PATTERN】** define the track of the current pattern
- **【RUN PATTERN】** run current pattern
- **【CLEAR PATTERN】** clear current pattern
- **【EDIT PATTERN LABEL】** edit current pattern label

4. Choose pattern number: move the cursor to **【PATTERN NUMBER】**, press **【OPEN】**, pattern you choose as current pattern, the following operations aim at the current pattern;

5. Define current pattern tour: move the cursor to **【PROGRAM PATTERN】**, press **【OPEN】** to set pattern track, move the image wantonly, and draw the focus. The dome has a tour that is not less than 180s, a series of park time, magnification, focus will be recorded, press **【OPEN】** to save.

6. Run pattern: Operate joystick to **【RUN PATTERN】**, press **【OPEN】** to run, the dome will continuously and repeatedly record the specific track.



NOTICE

When carry out program, run, clear pattern and edit label, should choose pattern number at first.

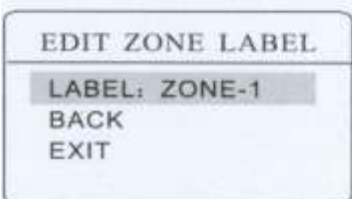
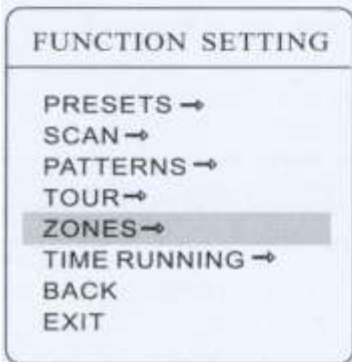
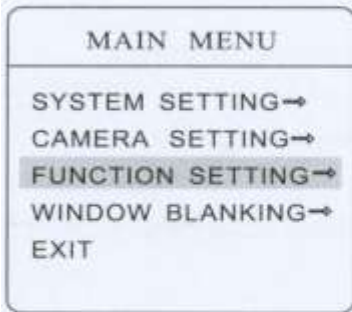

7.5 Zone setting

A dome may be set up to 8 zones; the regional scene can't be overlapped. User will set label for each zone. When setting **【ZONE LABEL】** as ON, the dome will display zone label as it runs some zone. It is convenient to know the zone that the camera shoots by setting zone label.

1、 The system enters into the main menu by calling 95 preset or by calling 9 preset twice within 3 seconds.

2、 Operate joystick, move the cursor to **【FUNCTION SETTING】**, press **【OPEN】** to enter submenu.

3、 Operate joystick, move the cursor to **【ZONES】**, press **【OPEN】** to enter submenu, as the left picture shows.

- **【ZONES NUMBER】** choose zone number as current zone, there choices in the menu aim at current zone.
- **【SET LEFT LIMIT】** set current zone's left limit
- **【SET RIGHT LIMIT】** set current zone's right limit
- **【CLEAR ZONE】** clear current zone setting
- **【EDIT ZONE LABEL】** edit current zone label, as zone number is 1. Zone label will auto-change as ZONE-1

Regard the left/right limit as the demarcation line, and set the middle part as a zone. Various operational ways are the same as other settings in the menu. Therefore we won't explain it again.

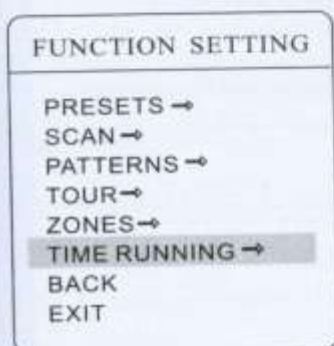
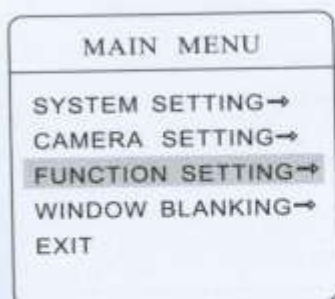

7. 6 Time Running Setting

1. The system enters into the main menu by calling 95 preset or by calling 9 preset twice within 3 seconds.
2. Operate joystick, move the cursor to **【FUNCTION SETTING】** , press **【OPEN】** to call the submenu.
3. Operate joystick, move the cursor to **【TIME RUNNING】** , Tilt up and down the joystick to set time channel, this seystem can set up to 4 time channels, press **【OPEN】** , the time channel that you choose is the current time channel, the following operations is only for current time channel.
4. Set the start and end of the time: move the cursor to **【START TIME】** , by tilting up and down the joystick to set the start time, press **【OPEN】** to save; move the cursor to **【END TIME】** , by tilting up and down the joystick to set the end time, press **【OPEN】** to save.
5. Motion setting: operate joystick, move the cursor to **【RUNNING】** , press **【OPEN】** , there will be a sign"⚙️" to display in the front of **【RUNGING】** , the cursor jumps to right, tilt up and down the joystick to choose the motion in corresponding time channel, press **【OPEN】** to save. The following items can be selected.

8. Privacy zone masking

Privacy function can show someone piece of regional shielding while protecting. For example, protect the window of bedroom or ATM of bank. A dome can set up to 24 privacy windows. (Masking setting function is relative with the model of camera module. The masking numbers will be different according to the different cameras.)

It can be set 24 masking window at most in 360° surveillance range; when the dome rotates down in the level $\geq 20^\circ$, can't set masking window.

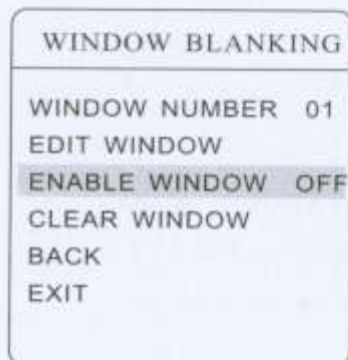
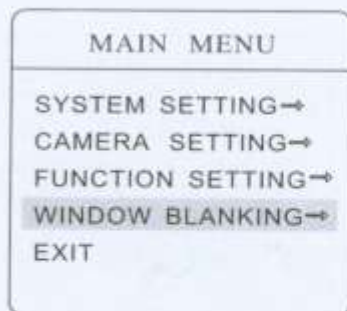

1. The system enters into the main menu by calling 95 preset or by calling 9 preset twice within 3 seconds.
2. Operate joystick to **【WINDOW BLANKING】**, press **【OPEN】** to enter menu " window blanking ".
 - **【WINDOW NUMBER】** choose window number as current privacy window, other choices in the menu just aim at current privacy window;
 - **【EDIT WINDOW】** program current window;
 - **【ENABLE WINDOW】** permit/prohibit current privacy window, there are two choices: ON---permit current privacy window/OFF---prohibit current privacy window
 - **【CLEAR WINDOW】** clear current privacy window, after clearing it, the window will auto- change as OFF.
3. Program current privacy window: Firstly choose window number, then do the following operations:
 - a. Operate joystick, move the cursor to **【EDIT WINDOW】**, press **【OPEN】** to move the image that need privacy window to display in the screen.
 - b. Press **【OPEN】**, there will be a square displaying in the centre of the screen, operate joystick, and move the square to the central place that need to conceal.
 - c. Press **【OPEN】**, operate joystick to adjust the size of privacy zone: joystick to up, the height is increased; joystick to down, the height is reduced; joystick to right, the width is increased; joystick to left, the width is reduced.
 - d. Press **【OPEN】** to save the current privacy zone setting, and the window will auto-change as ON at the same time.

Privacy zone masking



9. Appendix

9.1 Dome menu index

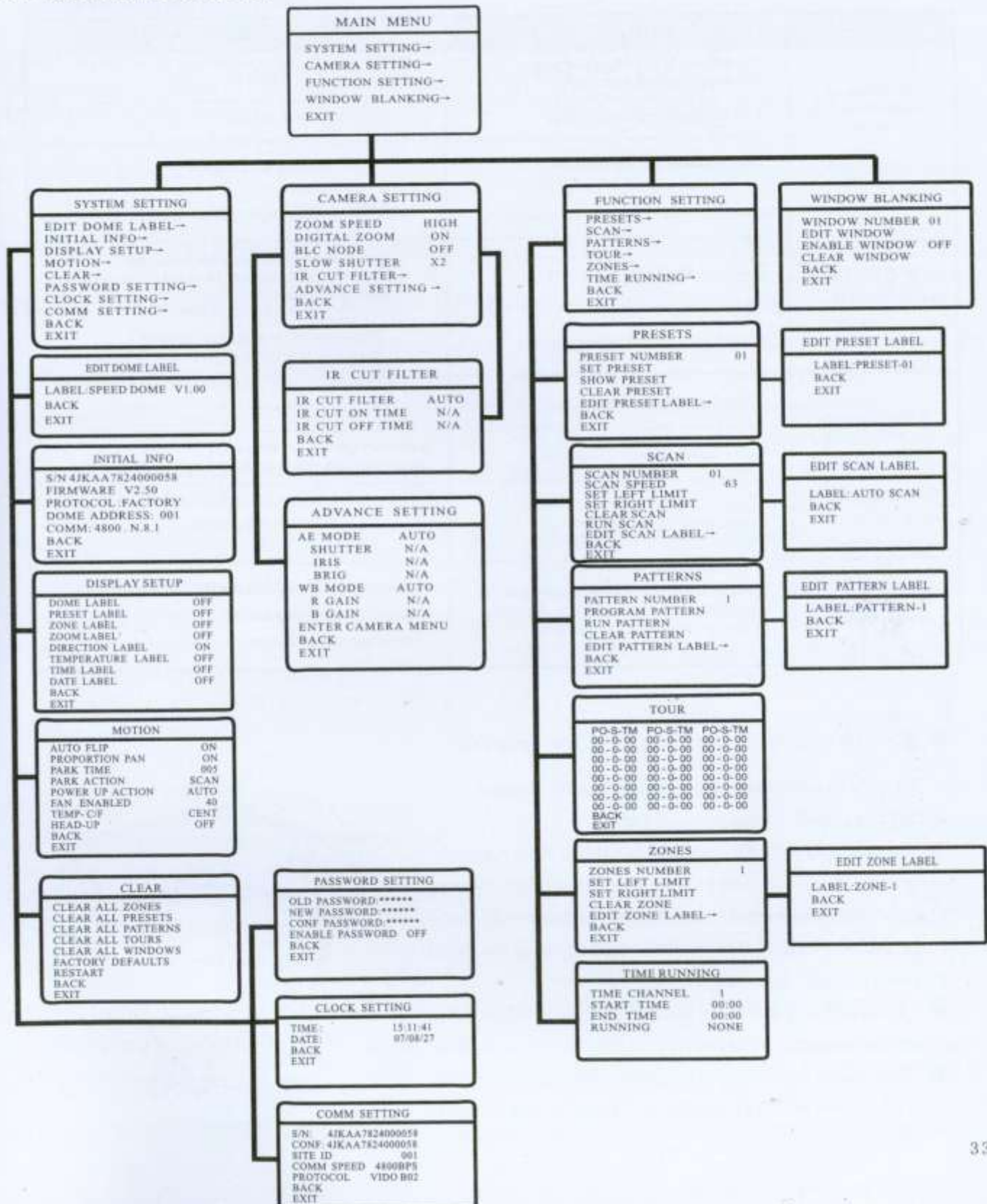

9. 2 Trouble shooting

Trouble	Possible causes	Solution
No action, no video after power up	Power supply is damage or power consumption is not enough	Replace
	Power line is bad connection	Correct
	Engineering line is malfunction	Check and repair
Self-testing and image are normal but the dome is uncontrollable	The dome DIP switch setting is incorrect	Refer to switch setting, reset the switch
	Rs485 may carve out a way	Check Rs485connection, confirm the connection is correct and good in contact
	Rs485 is in malfunction	Pls consult appendix "Rs485 Bus acknowledge"
Video image is not steady.	Video line is bad connection	Eliminate
	Power consumption is not enough	Replace right power adapter, it is better to put the switch and power adapter near the dome
Video image is not steady and the motor is malfunction	Power consumption is not enough	Replace the power
Dome controlling is not smooth.	Controlling line is bad connection Rs485 loads so many or the distance of communication is much far	1.Connect 120Ω resistance in the dome pan/tilt that is far from the controller 2.Increase distributor

9.3 The cleaning of clear down cover

To obtain constant clear videos, user should clean the down cover periodically.

- Be caution when cleaning, hold the down cover ring only to a void direct touch to the acrylic down cover. The acid sweat mark of fingerprint will corode the coating of down cover and scratch on down cover will cause vague image.
- Use soft dry cloth or the substitute to clean the inner and outer surfaces
- For hand contamination, use neutral detergent. Any cleanser for high grade furniture is applicable.



9. 4 Rs485Bus basic knowledge

> Characteristics of Rs485 Bus

As specified by Rs485 standard, Rs485 Bus is of half-duplex data transmission cables with characteristic impedance as 120 Ω. The maximum load capacity is 32unit loads(including main controller and controller equipment)

> Transmission distances of Rs485 Bus

When user selects the 0.56mm(24AWG) twisted pair wires as data transmission cable, the maximum theoretical transmitting distance are as follow:

Baud rate	Max distance
2400BPS	1800m
4800BPS	1200m
9600BPS	800m
19200BPS	600m

If user selects thinner cables, or installs the dome in an environment with strong electromagnetic interference, or connects lots of equipment to the Rs485Bus, the maximum transmitting distance will be decreased. To increase the maximum transmitting distance, do the contrary.

> Connection and termination resistor

The Rs485Bus standards require a daisy-chain connection between the equipment. There must be termination resistors with 120 Ω (as the picture9-4.1). Please refer to picture 9-4.2 for simple connection. D should not exceed 7m.

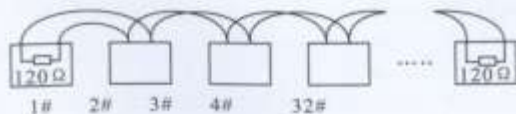

Picture9-4.1

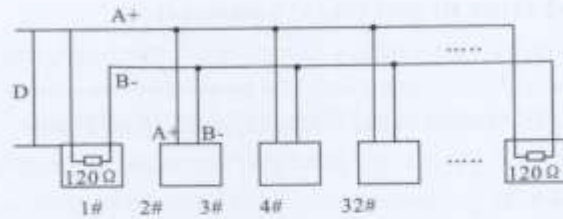

Picture9-4.2

> The connection of 120 Ω termination resistor:

The termination resistor is ready on the protocol PCB. There are two kinds of connection (as show 9-4.3 form). It is the factory default connection. The jumper cap of switchboard is seated on pin 2 & Pin 3 and the termination resistor 120 Ω is not connected.

When connecting the 120 Ω termination resistor, user should pull out the protocol PCB and plug the jumper on Pin 1 & pin 2. Install the PCB back and the termination resistor is connected.

(as show the picture9-4.3)

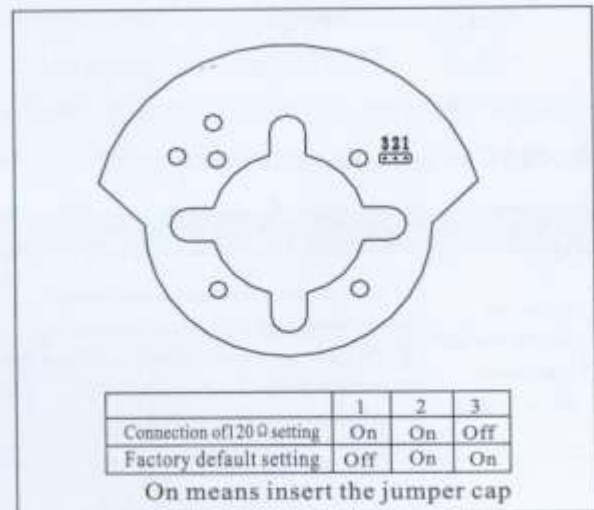

Picture9-4.3

> **Problems in practical connection**

In some circumstances user adopts a star configuration in practical connection. The termination resistors must be connected to the two equipment 1# and 5# in picture 9-4.4. As the star configuration is not in conformity with the requirements of Rs485 standards, problems such as signal reflections, lower anti-interference performance arise when the cables are long in the connection. Thereliability of control signals is decreased with the phenomena that the dome does not respond to or just responds at intervals to the controller, or does continuous operation without stop.

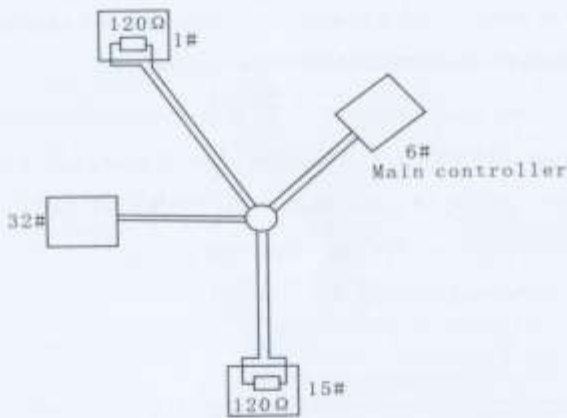

Picture9-4.4

In such circumstances the factory recommends the usages of Rs485 distributor. The distributor can change the star configuration connection to the mode of connection stipulated in the Rs485 standards. The new connection achieves reliable data transmission. (Refer to picture 9-4.5)

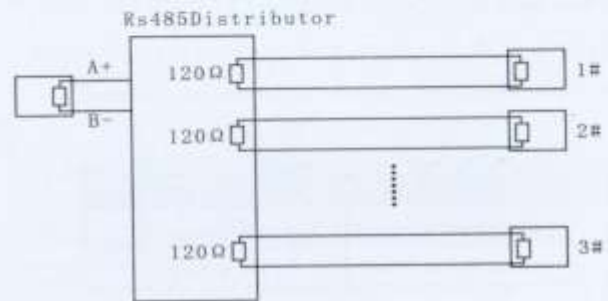

Picture 9-4.5

> **Rs485Bus troubles shooting**

Trouble	Possible cause	Solution
Dome can do self-testing but cannot be controlled	A. The address and baud rate setting of dome, are not in conformity with those of controller. B. The + and - connection of Rs485 Bus is incorrect. C. bad connection. D. there are circuit in the Rs485Bus.	A. Change the address and baud rate of controller or dome B. Adjust the + and -connection of Rs485; C. Make sure the connections are fully seated; D. Change Rs485 Bus wires
The dome can be controlled but the operation is not smooth	A. the Rs485Bus is not in good contact with the connectors. B. One wire of Rs485 bus is broken. C. The dome is very far from controller. D. There are two many domes connected in the system.	A. Secure the connection; B. Replace Rs485 bus wires C. Add termination resistors to the system D. Install Rs485 distributor

10. Maintenance service terms

1. Range of warranty

- The product will be maintained free for one year.
- The product will be obtained the free maintenance service if the same malfunction appears again within three months.
- Malfunction of products caused by force majeure (such as war, earthquake, lightning strike and so on), abuse, non-standard operation, change of construction, non-normal wear or accident are non-free of warranty.
- Please prevent from the damage which is caused by heavy pressure , the fierce vibration and soaks in the process of transportation and storage, which does not belong to the free maintenance scope.
- Please adopt the way of fission package or original package to transport because the product damage dose not belong to the free maintenance scope if you use the whole packing way , not the original packing way.
- The maintenance services will not be free when the pan/tilt module is disassembled or serviced by the user voluntarily.
- Our company implements the lifetime payable service if the product in malfunction has surpassed the warranty period.
- To the products with defect :if it's in the period of warranty, please fill in the form of warranty information correctly, describe the trouble in details , and provide the trouble in details , and provide original sales invoice or its copy.
- For the damage and loss which was caused by the user's specifically application, factory won't bear any risk and responsibility. The factory compensation made by breach of faith, negligence or tortious won't exceed the amount of the products. The factory won't bear any responsibility for the special, unexpected and continue damage caused by any other reasons.
- Our company has the final right of explanation for the above terms.

2. Warranty terms

- If the products are within the warranty time, the buyer should fill in the warranty card and send back together with the products.

3. Shipping

- If the product needs repaired , you can return it to the manufacturer through the supplier or directly. If you choose the later , please contact us in order to speed up the process. And our company only undertake the one-way freight from manufacturer to customer after maintenance.